

OCMP, OCMO, OCMY SERIES TRANSFORMERS

Transformers of OCMP series (O – single-phase, C – dry-type, M – multifunctional, P – isolating) rating 0.063...10 kVA, OCMO series (single-phase, dry-type, multifunctional, O – separating, of general use) rating 0.063...1.0 kVA, OCMY series (single-phase, dry-type, multifunctional, Y – for power supply to control circuits) rating 0.4...1.0 kVA, with rated voltage not more than 1000 V a. c. of industrial frequency, are intended for power supply to control circuits, local lighting circuits, signaling and automation circuits.



Transformers comply with the requirements of STB IEC 61558-1 standard.

OCMO transformers meet IEC 61558-2-1 standard.

OCMY transformers meet IEC 61558-2-2 and STB IEC 61558-2-6 standards.

OCMP transformers meet IEC 61558-2-4 and STB IEC 61558-2-6 standards.

Climatic versions are CT, C and MWDr as to IEC 60721-2-1:2002 standard.

Transformers are designed for indoor operation at altitudes above sea level not more than 1000 m (transformers operation is allowed at altitudes up to 3000 m above sea level, but in such a case the load power shall decrease for 2.5 % every 500 m).

According to their mobility the transformers are stationary ones.

As to installation conditions on worksite, the transformers are incorporated ones.

Transformers with the power of up to 0.4 kVA inclusive are to be mounted on a horizontal or vertical plane (for M9 group of mechanical performance); transformers with the power from 0.4 up to 2.5 kVA inclusive are to be mounted on a horizontal plane (for M9 group of mechanical performance); transformers with the power of 0.63 and 1.0 kVA are to be mounted on a vertical plane (for M8 group of mechanical performance); transformers with the power 4.0; 6.3 and 10 kVA are to be mounted on a horizontal plane (for M1 group of mechanical performance).

Insulation thermal-endurance class – B as to GOST 8865-93.

All the transformer parts made from dielectric materials are resistant against inflammation and flame propagation.

The same type transformers of various climatic versions have completely identical electrical parameters and differ by protective coatings only.

The corrected sound power level of the transformers both under no-load run and under rated load does not exceed 49 dBA for the transformers with the power of up to 2.5 kVA, and 60 dBA for 4.0; 6.3 and 10 kVA transformers.

As to protection against electric-shock hazard the transformers belong to I class in accordance with GOST 12.2.007.0-75 and have IP00 protection degree in accordance with GOST 14254-96. Contact terminals are of IP20 protection degree.

BASIC SPECIFICATIONS OF THE TRANSFORMERS

Transformer type	Rated power, kVA	Short-circuit voltage, U_k , %			Efficiency factor, %, not less than			
		for two-winding transformer	for three-winding transformer					
			for U_{K1-2}	for U_{K1-3}				
OCMO-0.063 OCMP-0.063	0.063	—	—	—	79.0			
OCMO-0.1 OCMP-0.1	0.100				82.4			
OCMO-0.16 OCMP-0.16	0.160				86.0			
OCMO-0.25 OCMP-0.25	0.250				88.1			
OCMO-0.4 OCMY-0.4 OCMP-0.4	0.400				89.5			
OCMO-0.63 OCMY-0.63 OCMP-0.63	0.630				90.7			
OCMO-1.0 OCMY-1.0 OCMP-1.0	1.000				91.8			
OCMP-1.6	1.600				3.05	2.90	2.10	92.2
OCMP-2.5	2.500				2.75	5.85	2.05	93.2
OCMP-4.0	4.000				2.70	—	—	94.5
OCMP-6.3	6.300	2.10	94.8					
OCMP-10	10.000	1.90	95.3					

TRANSFORMER CONNECTION DIAGRAMS, WINDING CONNECTION / VECTOR GROUPS AND VOLTAGES

*Three-winding OCMP series transformer with tapplings on secondary winding**

Transformer connection diagram	Transformer type	Rated power of secondary winding, kVA		Windings rated voltage, V			Winding connection / vector group
		U_2	U_3	of primary U_1	of secondary		
					U_2	U_3	
	OCMP-0.1	0.075	0.025	220; 380; 400; 415; 440; 660	110; 220; 230	12; 24; 36; 42; 110	1/1/1-0-0
	OCMP-0.16	0.100	0.060				
	OCMP-0.25	0.190					
	OCMP-0.4	0.340					
	OCMP-0.63	0.510	0.120				
	OCMP-1.0	0.880					
	OCMP-1.6	1.350	0.250				
	OCMP-2.5	2.250					

* The power of the transformer secondary winding tapplings decreases against the power of the whole winding proportionally to the voltage decreasing.

Two-winding OCMP series transformer with tapings on secondary winding*

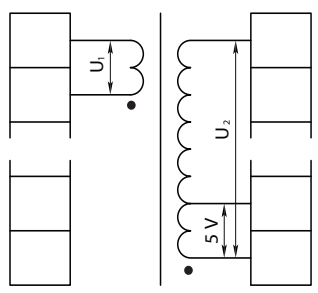
Transformer connection diagram	Transformer type	Rated power of secondary winding, kVA	Windings rated voltage, V		Winding connection / vector group
			of primary, U ₁	of secondary, U ₂	
	OCMP-0.063	0.063	220; 230; 380; 400; 415; 440; 660	10; 12; 14; 24; 29; 36; 42; 56; 110; 130; 220; 230; 260	1/1-0
	OCMP-0.1	0.100		12; 14; 24; 29; 36; 42; 56;	
	OCMP-0.16	0.160		110; 130; 220; 230; 260	
	OCMP-0.25	0.250		24; 36; 42; 110; 220	
	OCMP-0.4	0.400			
	OCMP-0.63	0.630			
	OCMP-1.0	1.000			

* The power of the transformer secondary winding tapings decreases against the power of the whole winding proportionally to the voltage decreasing.

OCMP, OCMO series three-winding transformer

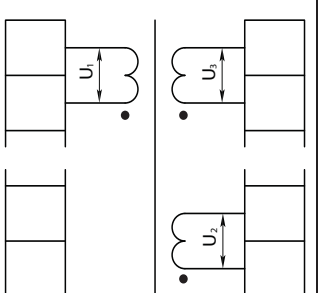
Transformer connection diagram	Transformer type	Rated power of secondary winding, kVA		Windings rated voltage, V			Winding connection / vector group
		U ₂	U ₃	of primary, U ₁	of secondary*, U ₂ , U ₃		
					for OCMP	for OCMO	
	OCMO-0.063 OCMP-0.063	0.0315	0.0315	110; 220; 380	14; 24; 29; 56; 82	56; 82	1/1/1-0-0
	OCMO-0.1 OCMP-0.1						
	OCMO-0.16 OCMP-0.16	0.080	0.080	110; 220; 230; 380; 660	12; 14; 24; 29; 56; 82		
	OCMO-0.25 OCMP-0.25						
	OCMO-0.4 OCMP-0.4	0.200	0.200	220; 380	12		
	OCMO-0.63 OCMP-0.63						
	OCMO-1.0 OCMP-1.0	0.500	0.500		12		
	OCMP-2.5						

* Two similar windings.

OCMY series three-winding transformer

Transformer connection diagram	Transformer type	Rated power of secondary winding, kVA		Windings rated voltage, V			Winding connection / vector group
		U ₂	U ₃	of primary, U ₁	of secondary		
					control, U ₂	U ₃	
	OCMY-0.4	0.340	0.060	220; 380;	110; 220; 230	12; 24;	1/1/1-0-0
	OCMY-0.63	0.510	0.120	400; 415;		36; 42;	
	OCMY-1.0	0.880	0.120	440; 660		110	

OCMP series four-winding transformer

Transformer connection diagram	Transformer type	Rated power of secondary winding, kVA			Windings rated voltage, V				Winding connection / vector group
		U ₂	U ₃	U ₄	of primary, U ₁	of secondary			
						U ₂	U ₃	U ₄	
	OCMP-0.1	0.025	0.050	0.025	220; 380	110	29	12; 24	1/1/1-0-0-0
	OCMP-0.16	0.075	0.060					12; 24; 42	
	OCMP-0.25	0.100	0.090	0.060	220; 380; 415			12; 24; 36; 42	
	OCMP-0.4	0.190	0.150					12; 24; 42	
	OCMP-0.63	0.340	0.230					220; 380	

OCMY series four-winding transformer

Transformer connection diagram	Transformer type	Rated power of secondary winding, kVA			Windings rated voltage, V				Winding connection / vector group
		U ₂	U ₃	U ₄	of primary, U ₁	of secondary			
						control, U ₂	control, U ₃	U ₄	
	OCMY-0.4	0.190	0.150	0.060	220; 380; 415;	110	29	12; 24; 42	1/1/1-0-0-0
	OCMY-0.63	0.340	0.230		220; 380;				

Two-winding transformer

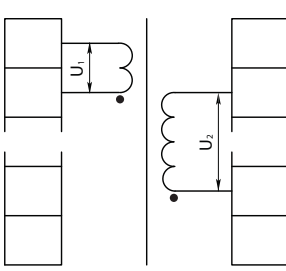
Transformer connection diagram	Transformer type	Rated power of secondary winding, kVA	Windings rated voltage, V			Winding connection / vector group	
			of primary, U_1	of secondary			
				U_2			control U_2
for OCMP	for OCMO	for OCMY					
	OCMO-0.063 OCMP-0.063	0.063				1/1-0	
	OCMO-0.1 OCMP-0.1	0.100					
	OCMO-0.16 OCMP-0.16	0.160		12; 14; 24;			—
	OCMO-0.25 OCMP-0.25	0.250	220; 380; 400;	29; 36; 42;	56; 110; 130;		
	OCMO-0.4 OCMY-0.4 OCMP-0.4	0.400	415; 440; 660	56; 110;	220; 260		14; 29;
	OCMO-0.63 OCMY-0.63 OCMP-0.63	0.630		30; 220; 260			56; 110; 130; 220; 260
	OCMO-1.0 OCMY-1.0 OCMP-1.0	1.000					
	OCMP-1.6	1.600	220; 380; 660	12; 24; 29; 36; 42; 110; 220			
	OCMP-2.5	2.500		24; 36; 42; 110; 220			
	OCMP-4.0	4.000	220; 230; 380; 400	36; 42; 110; 115; 220; 230; 380; 400	—		—
	OCMP-6.3	6.300		110; 115; 220; 230;			
	OCMP-10	10.000		380; 400			

OVERALL, MOUNTING DIMENSIONS AND MASS OF THE TRANSFORMERS

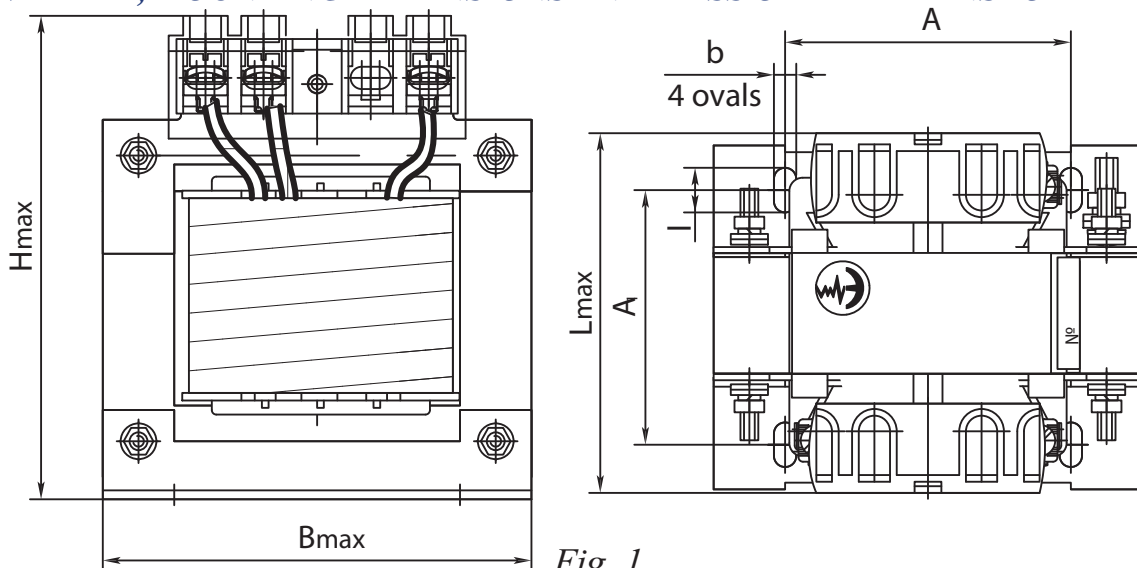

Fig. 1

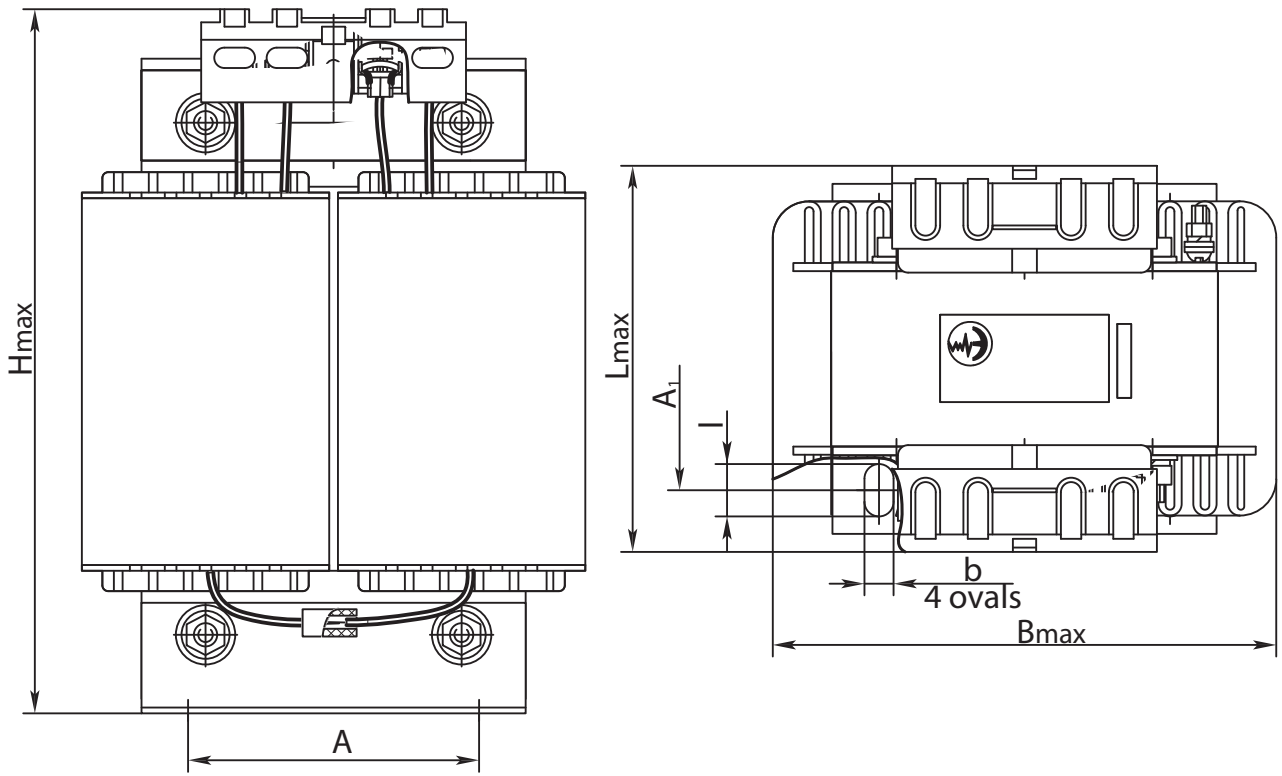

Fig. 2

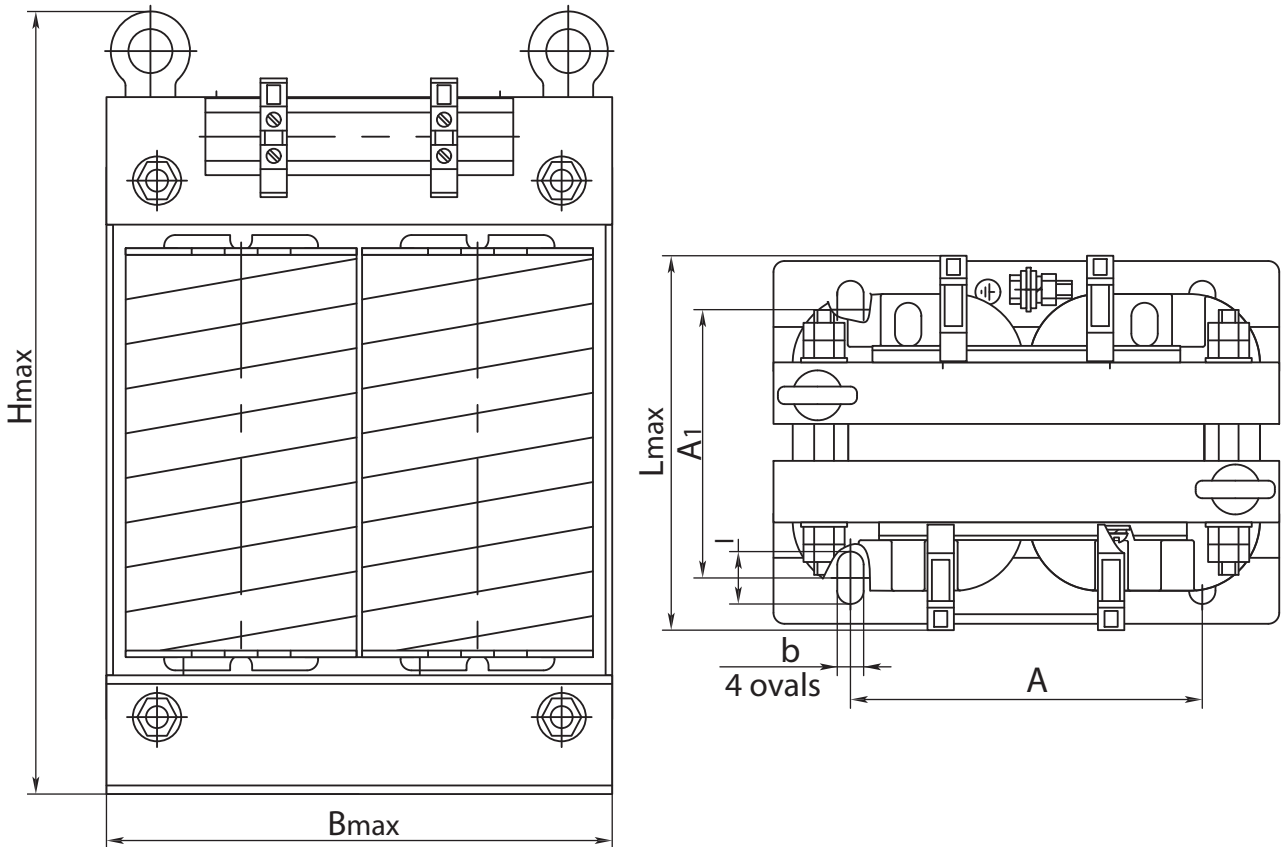

Fig. 3

dimensions in mm

Transformer type	Bmax	Lmax	Hmax	A	A ₁	b	l	Mass, kg	Fig.	
OCMO-0.063 OCMP-0.063	77	95	100	56 ± 1	54 ± 2	5 ⁺¹	10 ⁺¹	1.36	1	
OCMO-0.1 OCMP-0.1	98	90	110	64 ± 1	57 ± 2			1.96		
OCMO-0.16 OCMP-0.16		95		65 ± 2	2.46					
OCMO-0.25 OCMP-0.25	107	100	120	80 ± 1	71 ± 2	6 ⁺¹	12 ⁺¹	3.57		
OCMO-0.4 OCMY-0.4 OCMP-0.4	122	130	140	90 ± 1	85 ± 2		10 ⁺¹	5.44		
OCMO-0.63 OCMY-0.63 OCMP-0.63	152		165	104 ± 1	90 ± 2	7 ⁺¹	12 ⁺¹	8.05		
OCMO-1.0 OCMY-1.0 OCMP-1.0	175	140	180	135 ± 1	101 ± 2		14 ⁺¹	13.10		
OCMP-1.6	175	143	246	100 ± 1	97 ± 1	10 ⁺¹	15 ⁺¹	16.90		2
		158*	260*							
OCMP-2.5	200	134	276	120 ± 1	89 ± 1			20.50		
		150*	283*							
OCMP-4.0	230	183	365	160 ± 1	126 ± 2			12 ^{+0.4}	24 ⁺¹	37.50
OCMP-6.3		221			164 ± 2	53.70				
OCMP-10		320			201	410	214 ± 1			146 ± 2

* For versions given in the Tables for three-winding and two-winding transformers with secondary voltage of 40 V max for transformers of 1.6 kVA power, and 62 V max for transformers of 2.5 kVA power.

Sample of notation (to place an order, or to refer to) for OCMP transformer of 0.25 kVA power rating, of 380 V primary winding voltage, of 110 V secondary winding voltage with 5 V and 22 V tapplings, of 12 V third winding voltage, of CT climatic version:

Transformer OCMP-0,25 Y3 380/5-22-110/12 TY PB 100211261.062-2009
(where TY PB = Technical Specifications of the Republic of Belarus).